

## DZ/DZQ系列真空(充气)包装机

### Semi-automatic vacuum packager

捆霸牌系列真空机广泛应用于各类食品、五金、医药、化工、水产品、电子元器件等行业，适合各种形态产品（固态、液态、粉末、糊状）的真空包装。可有效防止产品因氧化或者细菌繁殖引起的腐败变质，从而达到延长产品保和存储时间的目的。

台式真空机  
Table type vacuum packager

### DZ-260/PD

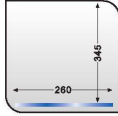

技术参数 Technology Parameters	
型号/Model	DZ-260/PD
电源电压/Power Supply	AC 220V/50Hz 110V/60Hz
电机功率/Power Consumption	0.37kw
热封功率/Heat Sealing Power	0.15kw
真空极限压力/Ultimate Vacuum	0.05hPa(mbar)
真空泵抽气速率/Pump Capacity	14.4m <sup>3</sup> /h
封热长度/Sealing Length	260mm
封热宽度/Sealing Width	5mm
真空室深度/Vacuum Chamber Depth	50mm
机器尺寸/Machine Size	502 × 330 × 380mm
外包装尺寸/Shipmnet Dimension	590 × 405 × 450mm
净重毛重/N.W&G.W	37.2kg/46kg

台式真空机  
Table type vacuum packager

### DZ-300/PD

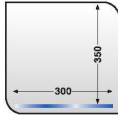

技术参数 Technology Parameters	
型号/Model	DZ-300/PD
电源电压/Power Supply	AC 220V/50Hz 110V/60Hz
电机功率/Power Consumption	0.37kw
热封功率/Heat Sealing Power	0.15kw
真空极限压力/Ultimate Vacuum	0.05hPa(mbar)
真空泵抽气速率/Pump Capacity	14.4m <sup>3</sup> /h
封热长度/Sealing Length	300mm
封热宽度/Sealing Width	5mm
真空室深度/Vacuum Chamber Depth	50mm
机器尺寸/Machine Size	525 × 400 × 380mm
外包装尺寸/Shipmnet Dimension	615 × 475 × 450mm
净重毛重/N.W&G.W	40kg/49kg

台式真空机  
Table type vacuum packager

### DZ-400/ZT

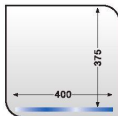

技术参数 Technology Parameters	
型号/Model	DZ-400/ZT
电源电压/Power Supply	AC 220V/50Hz 110V/60Hz
电机功率/Power Consumption	0.90kw
热封功率/Heat Sealing Power	0.60kw
真空极限压力/Ultimate Vacuum	0.1hPa(mbar)
真空泵抽气速率/Pump Capacity	20m <sup>3</sup> /h
封热长度/Sealing Length	390mm
封热宽度/Sealing Width	10mm
真空室深度/Vacuum Chamber Depth	65mm
机器尺寸/Machine Size	540 × 490 × 500mm
外包装尺寸/Shipmnet Dimension	640 × 590 × 630mm
净重毛重/N.W&G.W	62.5kg/77.5kg

## DZ/DZQ系列真空机储物箱

### Semi-automatic vacuum packager storage box

KUNBA vacuum machine is widely used in various types of food, hardware, pharmaceuticals, chemicals, aquatic products, electronic components industries, various forms of products(solid, liquid, powder, paste)in vacuum-packed. Can prevent the product due to oxidation or spillage caused by bacterial growth to achieve the extension of product shelf-life and storage time purposes.

台式真空机储物箱  
Vacuum packager storage box

### DZ-260/PD箱



#### 技术参数 Technology Parameters

外型尺寸	505x330x525mm
------	---------------

台式真空机储物箱  
Vacuum packager storage box

### DZ-300/PD箱



#### 技术参数 Technology Parameters

外型尺寸	525x400x525mm
------	---------------

台式真空机储物箱  
Vacuum packager storage box

### DZ-400/ZT箱



#### 技术参数 Technology Parameters

外型尺寸	540x490x420mm
------	---------------

## DZ/DZQ系列真空(充气)包装机

### Semi-automatic vacuum packager

落地式真空机  
Vacuum packager

### DZ-400/2E



可选德国进口BUSCH真空泵  
Busch Pump Optional

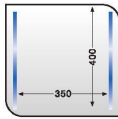

技术参数 Technology Parameters	
型号/Model	DZ-400/2E
电源电压/Power Supply	AC 220V/50Hz 110V/60Hz
电机功率/Power Consumption	0.90kw
热封功率/Heat Sealing Power	0.60kw
真空极限压力/Ultimate Vacuum	0.1hPa(mbar)
真空泵抽气速率/Pump Capacity	20m <sup>3</sup> /h
封热长度/Sealing Length	390mm
封热宽度/Sealing Width	10mm
真空室深度/Vacuum Chamber Depth	70mm
机器尺寸/Machine Size	540 × 490 × 960mm
外包装尺寸/Shipment Dimension	650 × 590 × 1010mm
净重毛重/N.W&G.W	70kg/87kg

落地式真空机  
Vacuum packager

### DZ-500/2E



可选德国进口BUSCH真空泵  
Busch Pump Optional

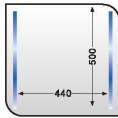

技术参数 Technology Parameters	
型号/Model	DZ-500/2E
电源电压/Power Supply	AC 220V/50Hz 110V/60Hz
电机功率/Power Consumption	0.90kw
热封功率/Heat Sealing Power	0.80kw
真空极限压力/Ultimate Vacuum	0.1hPa(mbar)
真空泵抽气速率/Pump Capacity	20m <sup>3</sup> /h
封热长度/Sealing Length	490mm
封热宽度/Sealing Width	10mm
真空室深度/Vacuum Chamber Depth	70mm
机器尺寸/Machine Size	640 × 570 × 970mm
外包装尺寸/Shipment Dimension	750 × 670 × 1080mm
净重毛重/N.W&G.W	97kg/117kg

落地式真空机  
Vacuum packager

### DZ-600/2E



可选德国进口BUSCH真空泵  
Busch Pump Optional

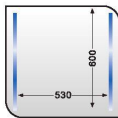

技术参数 Technology Parameters	
型号/Model	DZ-600/2E
电源电压/Power Supply	AC 380V/50Hz 220V/60Hz
电机功率/Power Consumption	1.50kw
热封功率/Heat Sealing Power	1.00kw
真空极限压力/Ultimate Vacuum	0.1hPa(mbar)
真空泵抽气速率/Pump Capacity	40m <sup>3</sup> /h
封热长度/Sealing Length	590mm
封热宽度/Sealing Width	10mm
真空室深度/Vacuum Chamber Depth	75mm
机器尺寸/Machine Size	742 × 672 × 910mm
外包装尺寸/Shipment Dimension	840 × 760 × 1110mm
净重毛重/N.W&G.W	151kg/178kg

## DZ/DZQ系列真空(充气)包装机

### Semi-automatic vacuum packager

双室真空机 (平板型)  
Double chamber vacuum packager (flat type)

### DZ-400/2SB



可选德国进口BUSCH真空泵  
Busch Pump Optional

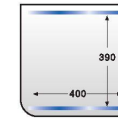

技术参数 Technology Parameters	
型号/Model	DZ-400/2SB
电源电压/Power Supply	AC 220V/50Hz 110V/60Hz
电机功率/Power Consumption	0.90kw
热封功率/Heat Sealing Power	0.60kw
真空极限压力/Ultimate Vacuum	0.1hPa(mbar)
真空泵抽气速率/Pump Capacity	20m <sup>3</sup> /h
封热长度/Sealing Length	390mm
封热宽度/Sealing Width	10mm
机器尺寸/Machine Size	990 × 610 × 950mm
外包装尺寸/Shipment Dimension	1090 × 680 × 1020mm
净重毛重/N.W&G.W	131kg/155kg

双室真空机 (平板型)  
Double chamber vacuum packager (flat type)

### DZ-500/2SB



可选德国进口BUSCH真空泵  
Busch Pump Optional

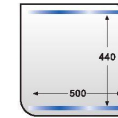

技术参数 Technology Parameters	
型号/Model	DZ-500/2SB
电源电压/Power Supply	AC 380V/50Hz 220V/60Hz
电机功率/Power Consumption	0.75kw × 2
热封功率/Heat Sealing Power	0.80kw
真空极限压力/Ultimate Vacuum	0.1hPa(mbar)
真空泵抽气速率/Pump Capacity	20m <sup>3</sup> /h × 2
封热长度/Sealing Length	490mm
封热宽度/Sealing Width	10mm
机器尺寸/Machine Size	1250 × 660 × 950mm
外包装尺寸/Shipment Dimension	1340 × 740 × 1030mm
净重毛重/N.W&G.W	174kg/224kg

双室真空机 (平板型)  
Double chamber vacuum packager (flat type)

### DZ-600/2SB



可选德国进口BUSCH真空泵  
Busch Pump Optional

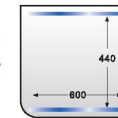

技术参数 Technology Parameters	
型号/Model	DZ-600/2SB
电源电压/Power Supply	AC 380V/50Hz 220V/60Hz
电机功率/Power Consumption	1.50kw
热封功率/Heat Sealing Power	1.00kw
真空极限压力/Ultimate Vacuum	0.1hPa(mbar)
真空泵抽气速率/Pump Capacity	40m <sup>3</sup> /h
封热长度/Sealing Length	590mm
封热宽度/Sealing Width	10mm
机器尺寸/Machine Size	1450 × 660 × 950mm
外包装尺寸/Shipment Dimension	1530 × 740 × 1020mm
净重毛重/N.W&G.W	220kg/272kg

## DZ/DZQ系列真空(充气)包装机

Semi-automatic vacuum packager

## DZ/DZQ系列真空(充气)包装机

Semi-automatic vacuum packager

### 双室真空机 (加深型)

Double chamber vacuum packager (deep type)

### DZ-400/2SA



可选德国进口BUSCH真空泵  
Busch Pump Optional

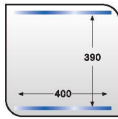

#### 技术参数 Technology Parameters

型号/Model	DZ-400/2SA
电源电压/Power Supply	AC 220V/50Hz 110V/60Hz
电机功率/Power Consumption	0.90kw
热封功率/Heat Sealing Power	0.60kw
真空极限压力/Ultimate Vacuum	0.1hPa(mbar)
真空泵抽气速率/Pump Capacity	20m <sup>3</sup> /h
封热长度/Sealing Length	390mm
封热宽度/Sealing Width	10mm
真空室深度/Vacuum Chamber Depth	40mm
机器尺寸/Machine Size	995 x 615 x 960mm
外包装尺寸/Shipment Dimension	1090 x 680 x 1020mm
净重毛重/N.W&G.W	129kg/153kg

### 双室真空机 (加深型)

Double chamber vacuum packager (deep type)

### DZ-500/2SA



可选德国进口BUSCH真空泵  
Busch Pump Optional

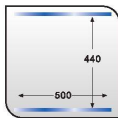

#### 技术参数 Technology Parameters

型号/Model	DZ-500/2SA
电源电压/Power Supply	AC 380V/50Hz 220V/60Hz
电机功率/Power Consumption	0.75kw x 2
热封功率/Heat Sealing Power	0.80kw
真空极限压力/Ultimate Vacuum	0.1hPa(mbar)
真空泵抽气速率/Pump Capacity	20m <sup>3</sup> /h x 2
封热长度/Sealing Length	490mm
封热宽度/Sealing Width	10mm
真空室深度/Vacuum Chamber Depth	40mm
机器尺寸/Machine Size	1250 x 660 x 960mm
外包装尺寸/Shipment Dimension	1340 x 740 x 1030mm
净重毛重/N.W&G.W	182kg/232kg

### 双室真空机 (加深型)

Double chamber vacuum packager (deep type)

### DZ-600/2SA



可选德国进口BUSCH真空泵  
Busch Pump Optional

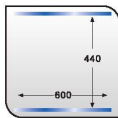

#### 技术参数 Technology Parameters

型号/Model	DZ-600/2SA
电源电压/Power Supply	AC 380V/50Hz 220V/60Hz
电机功率/Power Consumption	1.50kw
热封功率/Heat Sealing Power	1.00kw
真空极限压力/Ultimate Vacuum	0.1hPa(mbar)
真空泵抽气速率/Pump Capacity	40m <sup>3</sup> /h
封热长度/Sealing Length	590mm
封热宽度/Sealing Width	10mm
真空室深度/Vacuum Chamber Depth	40mm
机器尺寸/Machine Size	1450 x 660 x 960mm
外包装尺寸/Shipment Dimension	1530 x 740 x 1120mm
净重毛重/N.W&G.W	215kg/267kg

### 双室真空机 (四边封型)

Double chamber vacuum packager (with four sealing bars)

### DZ-650/4SB



可选德国进口BUSCH真空泵  
Busch Pump Optional

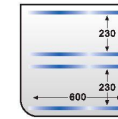

#### 技术参数 Technology Parameters

型号/Model	DZ-650/4SB
电源电压/Power Supply	AC 380V/50Hz 220V/60Hz
电机功率/Power Consumption	2.20kw
热封功率/Heat Sealing Power	1.20kw x 2
真空极限压力/Ultimate Vacuum	0.1hPa(mbar)
真空泵抽气速率/Pump Capacity	63m <sup>3</sup> /h
封热长度/Sealing Length	600mm
封热宽度/Sealing Width	10mm
机器尺寸/Machine Size	1450 x 895 x 960mm
外包装尺寸/Shipment Dimension	1540 x 985 x 1080mm
净重毛重/N.W&G.W	322kg/378kg

### 双室真空机 (平板型)

Double chamber vacuum packager (with flat chamber)

### DZ-700/2SB



可选德国进口BUSCH真空泵  
Busch Pump Optional

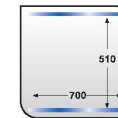

#### 技术参数 Technology Parameters

型号/Model	DZ-700/2SB
电源电压/Power Supply	AC 380V/50Hz 220V/60Hz
电机功率/Power Consumption	1.50kw
热封功率/Heat Sealing Power	1.20kw
真空极限压力/Ultimate Vacuum	0.1hPa(mbar)
真空泵抽气速率/Pump Capacity	40m <sup>3</sup> /h
封热长度/Sealing Length	690mm
封热宽度/Sealing Width	10mm
机器尺寸/Machine Size	1650 x 720 x 960mm
外包装尺寸/Shipment Dimension	1730 x 800 x 1120mm
净重毛重/N.W&G.W	267kg/330kg

### 可倾式真空机

Double chamber vacuum packager

### DZK-500/2SL

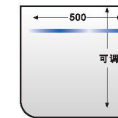

#### 技术参数 Technology Parameters

型号/Model	DZK-500/2SL
电源电压/Power Supply	AC 220V/50Hz 110V/60Hz
电机功率/Power Consumption	1.50kw
热封功率/Heat Sealing Power	0.60kw
真空极限压力/Ultimate Vacuum	0.1hPa(mbar)
真空泵抽气速率/Pump Capacity	20m <sup>3</sup> /h x 2
封热长度/Sealing Length	500mm
封热宽度/Sealing Width	10mm
机器尺寸/Machine Size	1690 x 710 x 1055mm
外包装尺寸/Shipment Dimension	1770 x 790 x 1220mm
净重毛重/N.W&G.W	220kg/272kg

油旋片式真空泵系列  
Oil rotary vane vacuum pump



品牌/Brand	KUNBA				
型号/Model	XD-020	V0040A	V0063A	V0100A	V0160A
抽气速率/Pump Capacity	20m³/h	40m³/h	63m³/h	100m³/h	160m³/h
极限压力/Ultimate Vacuum	0.1hPa	0.1hPa	0.1hPa	0.1hPa	0.1hPa
电机功率/Power Consumption	0.90kw	1.50kw	2.2kw	3.0kw	4.0kw
重量/Gross Weight	20kg	50kg	60kg	75kg	180kg

油旋片式真空泵系列  
Oil rotary vane vacuum pump



品牌/Brand	BUSCH 德国原装进口				
型号/Model	RA0021C	RA0040F	RA0063F	RA0100F	RA0160D
抽气速率/Pump Capacity	20m³/h	40m³/h	63m³/h	100m³/h	160m³/h
极限压力/Ultimate Vacuum	1/20hPa	0.1hPa	0.1hPa	0.1hPa	0.1hPa
电机功率/Power Consumption	0.75kw	1.10kw	1.5kw	2.2kw	4.0kw
重量/Gross Weight	20kg	40kg	60kg	100kg	160kg

外接泵系列  
External vacuum pump



品牌/Brand	KUNBA		
型号/Model	2X-15	2X-30A	2X-70A
抽气速率/Pump Capacity	54m³/h	108m³/h	252m³/h
极限压力/Ultimate Vacuum	0.1hPa	0.1hPa	0.1hPa
电机功率/Power Consumption	2.2kw	3.0kw	5.5kw
重量/Gross Weight	190kg	236kg	338kg

FJ 胶带封箱机系列  
Adhesive tape carton sealing machine

捆霸牌系列胶带封箱机广泛适用于各类纸箱的胶带封口包装，坚固耐用，封口牢固，能够大大提高厂家的包装效率，节约人力成本，是大批量生产的首选

KUNBA series carton sealer is widely used in various of carton sealing and packing, sturdiness and durability, sealing firm, it can help the manufacturers to enhance the efficiency, saving labor costs, is the preferred for mass production.

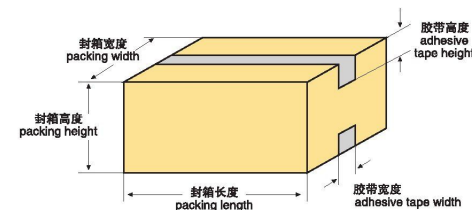

下驱动封箱机  
Bottom carton sealer driven

FJ-50



技术参数 Technology Parameters	
型号/Model	FJ-50
电源电压/Power Supply	AC 220V/50Hz 110V/60Hz
电机功率/Power Consumption	90W
输送速度/Conveyor Speed	≤20M/min
胶带尺寸/Adhesive Tape Width	48-60mm
封箱长度/Packing Length	≥200mm
封箱宽度/Packing Width	180-500mm
外包装尺寸/Shipment Dimension	980 × 820 × 730mm
净重/毛重/N.W&G.W	90Kg/110Kg

上下驱动封箱机  
Top-Bottom driven carton sealer

FJ-6050L

中国专利号:  
Z102258105.7  
FJ6050(轻鲁国)

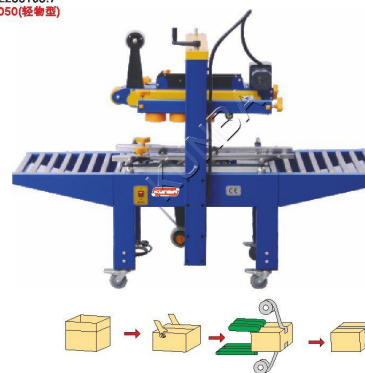

技术参数 Technology Parameters	
型号/Model	FJ-6050L
电源电压/Power Supply	AC 220V/50Hz 110V/60Hz
电机功率/Power Consumption	90W × 2
输送速度/Conveyor Speed	≤20M/min
胶带尺寸/Adhesive Tape Width	48-60mm
封箱长度/Packing Length	≥200mm
封箱宽度/Packing Width	180-500mm
封箱高度/Packing Height	110-650mm
外包装尺寸/Shipment Dimension	980 × 820 × 1190mm
净重/毛重/N.W&G.W	118Kg/153Kg

**FJ 胶带封箱机系列**  
Adhesive tape carton sealing machine

**左右驱动封箱机**  
Left-right driven carton sealer

**FJ-6050S**

中国专利号:  
Z102258105.7  
FJ6050S(传统型)

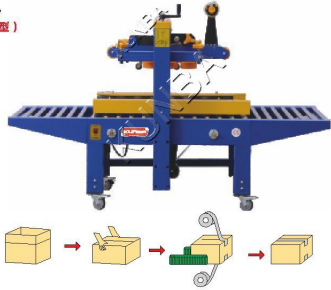

技术参数 Technology Parameters	
型号/Model	FJ-6050S
电源电压/Power Supply	AC 220V/50Hz 110V/60Hz
电机功率/Power Consumption	120W x 2
输送速度/Conveyor Speed	≤20M/min
胶带尺寸/Adhesive Tape Width	48-60mm
封箱长度/Packing Length	≥200mm
封箱宽度/Packing Width	100-500mm
封箱高度/Packing Height	110-650mm
外包装尺寸/Shipment Dimension	1170 x 1000 x 1190mm
净重/毛重/N.W&G.W	165Kg/225Kg

**上左右驱动封箱机**  
Top-left-right-driven carton sealer

**FJ-6050A**

中国专利号:  
Z102258105.7  
FJ6050A(全方位置)

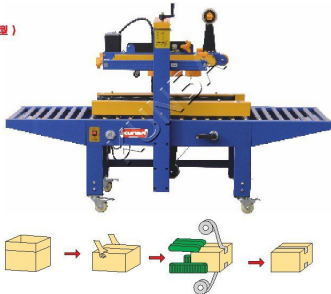

技术参数 Technology Parameters	
型号/Model	FJ-6050A
电源电压/Power Supply	AC 220V/50Hz 110V/60Hz
电机功率/Power Consumption	120W x 2 + 90W
输送速度/Conveyor Speed	≤20M/min
胶带尺寸/Adhesive Tape Width	48-60mm
封箱长度/Packing Length	≥200mm
封箱宽度/Packing Width	100-500mm
封箱高度/Packing Height	110-650mm
外包装尺寸/Shipment Dimension	1170 x 1000 x 1190mm
净重/毛重/N.W&G.W	168Kg/228Kg

**下左右驱动折盖封箱机**  
Bottom left-right driven flap case-sealing machine

**FJ-5050**

中国专利号:  
Z102258105.7  
FJ5050(自动折盖型)

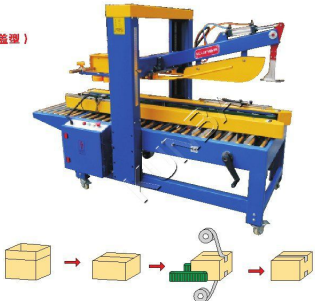

技术参数 Technology Parameters	
型号/Model	FJ-5050
电源电压/Power Supply	AC 220V/50Hz 110V/60Hz
电机功率/Power Consumption	200W x 2
输送速度/Conveyor Speed	≤20M/min
胶带尺寸/Adhesive Tape Width	48-60mm
封箱长度/Packing Length	200-650mm
封箱宽度/Packing Width	100-500mm
封箱高度/Packing Height	170-800mm
外包装尺寸/Shipment Dimension	2100 x 1150 x 1560mm
净重/毛重/N.W&G.W	274Kg/356Kg

**上下驱动侧封箱机**  
Top-bottom driven side carton sealer

**FJ-4042**

中国专利号:  
Z102258105.7  
FJ4042(侧封型)

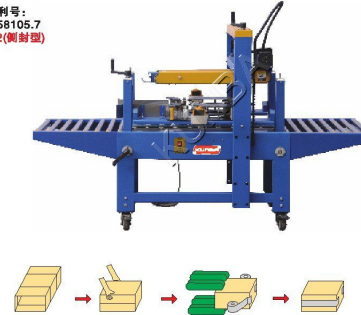

技术参数 Technology Parameters	
型号/Model	FJ-4042
电源电压/Power Supply	AC 220V/50Hz 110V/60Hz
电机功率/Power Consumption	120W + 90W
输送速度/Conveyor Speed	≤20M/min
胶带尺寸/Adhesive Tape Width	48-60mm
封箱长度/Packing Length	≥200mm
封箱宽度/Packing Width	150-430mm
封箱高度/Packing Height	100-450mm
外包装尺寸/Shipment Dimension	1170 x 1000 x 1190mm
净重/毛重/N.W&G.W	180Kg/240Kg

**全自动下左右驱动折盖封箱机**  
Top-bottom driven side carton sealer

**FJ-5050A**

中国专利号:  
Z102258105.7  
FJ5050A(自动折盖型)



技术参数 Technology Parameters	
型号/Model	FJ-5050A
电源电压/Power Supply	AC 220V/50Hz 110V/60Hz
电机功率/Power Consumption	250W x 2
输送速度/Conveyor Speed	≤20M/min
胶带尺寸/Adhesive Tape Width	48-60mm
封箱长度/Packing Length	200-650mm
封箱宽度/Packing Width	100-500mm
封箱高度/Packing Height	170-800mm
外包装尺寸/Shipment Dimension	2100 x 1150 x 1560mm
净重/毛重/N.W&G.W	285Kg/367Kg

## 输送线系列 Conveyor serials



无动力可伸缩输送线（滚筒型）  
Retractable conveyor without motor



SSX-D01 电动可伸缩输送线（滚筒型）  
SSX-D01 Retractable conveyor with motor



固定输送线  
Conveyor line



无动力可伸缩输送线（滚轮型）  
Retractable conveyor without motor

可伸缩正反转动输送线数字显示，速度可调；输送方向可调，正反转，伸缩长度890-2000mm

技术参数 Technology Parameters	
型号/Model	SSX-D01
电源电压/Power Supply	AC220/50Hz-110/60Hz
总功率/Consumption	360W
机器尺寸/Machine Size	900 x 900 x 570mm

## 多功能薄膜封口机 Multi-functional film sealer

中国专利号：ZL.02219651.X

KUNBA牌系列薄膜封口机适用于各种塑料薄膜的封口与制袋，广泛应用于食品、医药、化工、土特产品、化工、电子元件等行业，它是工厂、商店等部门使用的最佳封口设备

KUNBA series film sealing machine is suitable for sealing various plastic film and bag, which is widely used in food, medicine, chemicals, electronic components and other industries, it is the best sealing equipment for the factories, shops and other departments.

### 卧式薄膜封口机 Multi-functional film sealer (Horizontal)

### SF-150W

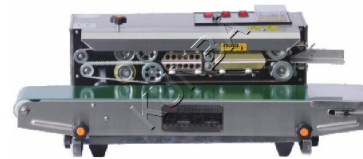

技术参数 Technology Parameters	
型号/Model	SF-150W
电源电压/Power Supply	AC220/50Hz 110V/60Hz
电机功率/Power Consumption	60W
电热功率/Heating Power	280W x 2
封口速度/Sealing Speed	0-16m/min (米/分)
封口宽度/Sealing Width	10mm
温控范围/Temperature Range	0-300°C
输送总承载/Conveyor Loading	≤5kg
外包装尺寸/Shipment Dimension	860 x 410 x 375mm
净重/毛重/N.W&G.W	20.5kg/23.5kg

### 落地式薄膜封口机 Multi-functional film sealer (Ground)

### SF-150LD



技术参数 Technology Parameters	
型号/Model	SF-150LD
电源电压/Power Supply	AC220/50Hz 110V/60Hz
电机功率/Power Consumption	60W
电热功率/Heating Power	280W x 2
封口速度/Sealing Speed	0-16m/min (米/分)
封口宽度/Sealing Width	10mm
温控范围/Temperature Range	0-300°C
输送总承载/Conveyor Loading	≤5kg
外包装尺寸/Shipment Dimension	965 x 430 x 445mm
净重/毛重/N.W&G.W	29.5kg/32.5kg

### 立式薄膜封口机 Multi-functional film sealer (Vertical)

### SF-150LW



技术参数 Technology Parameters	
型号/Model	SF-150LW
电源电压/Power Supply	AC220/50Hz 110V/60Hz
电机功率/Power Consumption	60W
电热功率/Heating Power	280W x 2
封口速度/Sealing Speed	0-16m/min (米/分)
封口宽度/Sealing Width	10mm
温控范围/Temperature Range	0-300°C
输送总承载/Conveyor Loading	≤5kg
外包装尺寸/Shipment Dimension	860 x 410 x 375mm
净重/毛重/N.W&G.W	23.5kg/26.5kg

墨轮印字薄膜封口机  
Solid-ink Printer film sealer

中国专利号: ZL.02219651.X

卧式墨轮印字封口机  
Solid-ink printer film sealer(Horizontal)

FRM-980W



技术参数 Technology Parameters	
型号/Model	FRM-980W
电源电压/Power Supply	AC220/50Hz 110V/60Hz
电机功率/Power Consumption	80W
封口电热功率/Heating Power	280W x 2
印字电热功率/Printing Power	60W x 2
封口速度/Sealing Speed	0-16m/min(米/分)
印字类别/Printing Material	固体墨轮/solid-ink
封口宽度/Sealing Width	10mm
温控范围/Temperature Range	0-300℃
输送总承载/Conveyor Loading	≤5Kg
外包装尺寸/Shipment Dimension	965 x 430 x 380mm
净重/毛重/N.W&G.W	25.5kg/28.5kg

落地式墨轮印字封口机  
Solid-ink printer film sealer(Ground)

FRM-980LD



技术参数 Technology Parameters	
型号/Model	FRM-980LD
电源电压/Power Supply	AC220/50Hz 110V/60Hz
电机功率/Power Consumption	80W
封口电热功率/Heating Power	280W x 2
印字电热功率/Printing Power	60W x 2
封口速度/Sealing Speed	0-16m/min(米/分)
印字类别/Printing Material	固体墨轮/solid-ink
封口宽度/Sealing Width	10mm
温控范围/Temperature Range	0-300℃
输送总承载/Conveyor Loading	≤5Kg
外包装尺寸/Shipment Dimension	965 x 430 x 445mm
净重/毛重/N.W&G.W	35.5kg/38.5kg

立式墨轮印字封口机  
Solid-ink printer film sealer(Vertical)

FRM-980LW



技术参数 Technology Parameters	
型号/Model	FRM-980LW
电源电压/Power Supply	AC220/50Hz 110V/60Hz
电机功率/Power Consumption	80W
封口电热功率/Heating Power	280W x 2
印字电热功率/Printing Power	60W x 2
封口速度/Sealing Speed	0-16m/min(米/分)
印字类别/Printing Material	固体墨轮/solid-ink
封口宽度/Sealing Width	10mm
温控范围/Temperature Range	0-300℃
输送总承载/Conveyor Loading	≤5Kg
外包装尺寸/Shipment Dimension	965 x 430 x 380mm
净重/毛重/N.W&G.W	28.7kg/31.7kg

墨轮印字(充气)封口机  
Solid-ink Printer film sealer

豪华型卧式墨轮印字封口机  
Solid-ink printer film sealer(Horizontal)

FRD-980AI



技术参数 Technology Parameters	
型号/Model	FRM-980AI
电源电压/Power Supply	AC220/50Hz 110V/60Hz
电机功率/Power Consumption	80W
封口电热功率/Heating Power	280W x 2
印字电热功率/Printing Power	60W x 2
封口速度/Sealing Speed	0-16m/min(米/分)
印字类别/Printing Material	固体墨轮/solid-ink
封口宽度/Sealing Width	10mm
温控范围/Temperature Range	0-300℃
输送总承载/Conveyor Loading	≤5Kg
外包装尺寸/Shipment Dimension	965 x 430 x 380mm
净重/毛重/N.W&G.W	27.15kg/30.3kg

豪华型落地式墨轮印字封口机  
Solid-ink printer film sealer(Ground)

FRD-980AIII



技术参数 Technology Parameters	
型号/Model	FRD-980AIII
电源电压/Power Supply	AC220/50Hz 110V/60Hz
电机功率/Power Consumption	80W
封口电热功率/Heating Power	280W x 2
印字电热功率/Printing Power	60W x 2
封口速度/Sealing Speed	0-16m/min(米/分)
印字类别/Printing Material	固体墨轮/solid-ink
封口宽度/Sealing Width	10mm
温控范围/Temperature Range	0-300℃
输送总承载/Conveyor Loading	≤5Kg
外包装尺寸/Shipment Dimension	965 x 430 x 445mm
净重/毛重/N.W&G.W	37.15kg/40.2kg

落地式充气薄膜封口机  
Air-filling film sealer

FRQM-980C

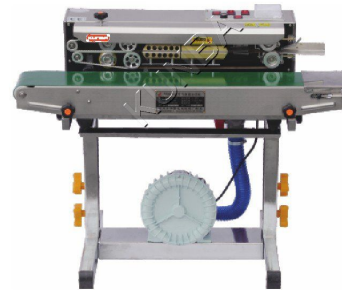

技术参数 Technology Parameters	
型号/Model	FRQM-980C
电源电压/Power Supply	AC220/50Hz 110V/60Hz
电机功率/Power Consumption	80W
气泵功率/Airpump Power	200W
封口电热功率/Heating Power	280W x 2
封口速度/Sealing Speed	0-16m/min(米/分)
封口宽度/Sealing Width	10mm
温控范围/Temperature Range	0-300℃
输送总承载/Conveyor Loading	≤5Kg
外包装尺寸/Shipment Dimension	1030 x 590 x 880mm
净重/毛重/N.W&G.W	41kg/48kg

印字薄膜封口机  
Multi-functional film sealer

保护型卧式薄膜封口机  
Horizontal film sealing machine with protection

SF-150WH



技术参数 Technology Parameters	
型号/Model	SF-150WH
电源电压/Power Supply	AC220/50Hz 110V/60Hz
电机功率/Power Consumption	60W
电热功率/Heating Power	280W × 2
封口速度/Sealing Speed	0-16m/min (米/分)
封口宽度/Sealing Width	10mm
温控范围/Temperature Range	0-300°C
输送总承载/Conveyor Loading	≤5kg
外包装尺寸/Shipment Dimension	860 × 410 × 375mm
净重/毛重/N.W&G.W	21.5kg/24.5kg

卧式色带打印印字薄膜封口机  
Horizontal ribbon film sealing machine

SF-150SD



技术参数 Technology Parameters	
型号/Model	SF-150SD
电源电压/Power Supply	AC220/50Hz 110V/60Hz
电机功率/Power Consumption	60W
电热功率/Heating Power	280W × 2
封口速度/Sealing Speed	0-16m/min (米/分)
封口宽度/Sealing Width	10mm
温控范围/Temperature Range	0-300°C
输送总承载/Conveyor Loading	≤5kg
外包装尺寸/Shipment Dimension	980 × 470 × 550mm
净重/毛重/N.W&G.W	30kg/47.8kg

充气气型卧式薄膜封口机  
Sufficient ammonia horizontal film sealing machine

FRQM-980CD

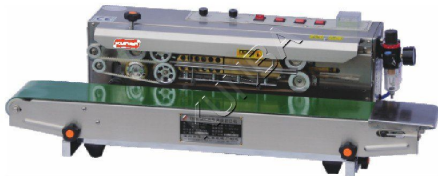

技术参数 Technology Parameters	
型号/Model	FRQM-980CD
电源电压/Power Supply	AC220/50Hz 110V/60Hz
电机功率/Power Consumption	80W
电热功率/Heating Power	280W × 2
封口速度/Sealing Speed	0-16m/min (米/分)
封口宽度/Sealing Width	10mm
温控范围/Temperature Range	0-300°C
输送总承载/Conveyor Loading	≤5kg
外包装尺寸/Shipment Dimension	965 × 430 × 380mm
净重/毛重/N.W&G.W	26.0kg/29.0kg

多功能薄膜封口机  
Multi-functional film sealer

气压大袋封口机  
Air pressure sealing machine

QF-600L

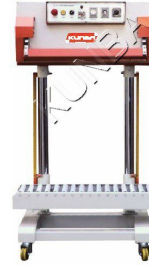

技术参数 Technology Parameters	
型号/Model	QF-600L
电源电压/Power Supply	AC220-240/50Hz
总功率/Power Consumption	500W
封口速度/Sealing Speed	0-13m/min(米/分)可调
封口宽度/Sealing Width	8-10mm
温控范围/Temperature Range	0-300°C
袋长范围/Bag Length Range	50-700mm可调
输送承载/Conveyor Loading	15kgs
外包装尺寸/Shipment Dimension	720 × 560 × 1340mm
毛重/Gross Weight	130kg
薄膜厚度/Sealing Film Thickness	0.10-0.80mm

多功能立式封口机  
Multi-functional film sealer(Vertical)

CBS-1100V



技术参数 Technology Parameters	
型号/Model	CBS-1100V
电源电压/Power Supply	220V single phase 50/60Hz
总功率/Power Consumption	750W
封口速度/Sealing Speed	0-12m/min
封口宽度/Sealing Width	5-10mm
薄膜厚度/Sealing Film Thickness	0.02-0.80mm
温控范围/Temperature Range	0-300°C
印字个数/Print Capacity	≤39
输送承载/Conveyor Loading	20kgs
外包装尺寸/Shipment Dimension	1100 × 610 × 1030mm
毛重/Gross Weight	122kg
可调高度/Adjustable Height	180-600mm

多功能卧式封口机  
Multi-functional film sealer(Horizontal)

CBS-1100H



技术参数 Technology Parameters	
型号/Model	CBS-1100H
电源电压/Power Supply	220V single phase 50/60Hz
总功率/Power Consumption	750W
封口速度/Sealing Speed	0-12m/min
封口宽度/Sealing Width	5-10mm
薄膜厚度/Sealing Film Thickness	0.02-0.80mm
温控范围/Temperature Range	0-300°C
印字个数/Print Capacity	≤39
输送承载/Conveyor Loading	20kg
外包装尺寸/Shipment Dimension	1100 × 610 × 1030mm
毛重/Gross Weight	122kg



## 连续封口机 Band Sealer



水平型连续封口机SPM-100S(专用封口)  
Horizontal Type Band Sealer(Only for Sealing)



水平型连续封口机SPM-100P(印字功能)  
Horizontal Type Band Sealer(With Printer)



SPM-100A竖直型连续式封口机(印字+抽气)  
Horizontal Type band Sealer(With Printer and Air Suction)



SPM-200P竖直型连续式封口机(印字)  
Vertical Type Band Sealer(With Printer)

### 技术参数 Technology Parameters

型号/Model	SPM-100S	SPM-100P	SPM-100A	SPM-200P
电源电压/Power Supply	220V Single phase 50/60HZ			
总功率/Power Consumption	840W	940W	1380W	940W
封口宽度/Sealing Width	10mm(5.12mm changeable)			
封口温度/Sealing Temperature	0~390°C			
传动速度/Conveyor Speed	Max.17M/m			
传动带尺寸/Conveyor Size	W200×L1390			W200×1450
封口带尺寸/Sealing Belt Size	W20×L1210	W200×L1210	w20×1390	W20×L1210
树脂带尺寸/Polymax Belt Size	5M×L457Mmm	5M×L950mm	5M×L950mm	5M×L950mm
体积/Dimension	W550×L1050×H1050			W700×L1450×H1500
重量/Weight(Kg)	75	95	115	135
印字机头型/Printer Type	-		Electric heat printer	

## 手压 / 脚踏封口机 Manual Sealer/Pedal Sealer



### 手压封口机(塑壳、铝壳) Manual Sealer(Plastic, Aluminum)

### PFS100-400

#### 技术参数 Technology Parameters

型号/Model	PFS100	PFS200	PFS300	PFS400
电源电压/Power Supply	AC110~220V/60~50Hz	AC110~220V/60~50Hz	AC110~220V/60~50Hz	AC110~220V/60~50Hz
总功率/Power Consumption	250W	300W	400W	600W
最大封口尺寸/Max Sealing Size	150mm	200mm	300mm	400mm
外包装尺寸/Shipment Dimension	72×220×140mm	80×320×150mm	80×450×180mm	85×550×180mm
毛重/Gross Weight	1.9kg	3.0kg	4.5kg	5.5kg

### 脚踏封口机(落地式) Pedal Sealer(Ground)

### PFS350-800JT

#### 技术参数 Technology Parameters

型号/Model	PFS350JT	PFS450JT	PFS600JT	PFS800JT
电源电压/Power Supply	AC110~220V/60~50Hz	AC110~220V/60~50Hz	AC110~220V/60~50Hz	AC110~220V/60~50Hz
总功率/Power Consumption	1200W	1250W	1500W	1800W
最大封口尺寸/Max Sealing Size	350mm	450mm	600mm	800mm
外包装尺寸/Shipment Dimension	880×550×250mm	880×550×250mm	880×550×250mm	920×550×250mm
毛重/Gross Weight	19kg	21kg	24.5kg	26kg

### 脚踏封口机(带打码) Pedal Sealer(With printer)

### PFS350-800JT

#### 技术参数 Technology Parameters

型号/Model	PFS350JT	PFS450JT	PFS600JT	PFS800JT
电源电压/Power Supply	AC110~220V/60~50Hz	AC110~220V/60~50Hz	AC110~220V/60~50Hz	AC110~220V/60~50Hz
总功率/Power Consumption	1500W	1700W	1900W	2100W
最大封口尺寸/Max Sealing Size	350mm	450mm	600mm	800mm
外包装尺寸/Shipment Dimension	880×550×250mm	880×550×250mm	880×550×250mm	920×550×250mm
毛重/Gross Weight	21kg	23kg	27kg	28kg

## 脚踏封口机 Pedal Sealer



脚踏封口机 (普通式)  
Pedal Sealer(Normal)

### FRS400-700JT

#### 技术参数 Technology Parameters

型号/Model	FRS400JT	FRS500JT	FRS600JT	FRS700JT
电源电压/Power Supply	AC110-220V/60-50Hz	AC110-220V/60-50Hz	AC110-220V/60-50Hz	AC110-220V/60-50Hz
总功率/Power Consumption	450W	550W	650W	750W
最大封口尺寸/Max Sealing Size	400mm	500mm	600mm	700mm
外包装尺寸/Shipment Dimension	730 x 390 x 200mm	730 x 390 x 200mm	830 x 390 x 200mm	830 x 390 x 200mm
毛重/Gross Weight	9.3kg	10.2kg	11.3kg	12.2kg

脚踏封口机(通过式)  
Pedal Sealer(Direct)

### FRS400-1000JT

#### 技术参数 Technology Parameters

型号/Model	FRS400JT	FRS500JT	FRS600JT	FRS700JT
电源电压/Power Supply	AC110-220V/60-50Hz	AC110-220V/60-50Hz	AC110-220V/60-50Hz	AC110-220V/60-50Hz
总功率/Power Consumption	450W	550W	650W	750W
最大封口尺寸/Max Sealing Size	400mm	500mm	600mm	700mm
外包装尺寸/Shipment Dimension	810 x 390 x 290mm	810 x 390 x 290mm	1100 x 390 x 290mm	1100 x 390 x 290mm
毛重/Gross Weight	11kg	12.5kg	13.5kg	14.5kg

脚踏封口机(带刀式)  
Pedal Sealer(With Knife)

### FRS400-800JT

#### 技术参数 Technology Parameters

型号/Model	DFS400JT	DFS500JT	DFS600JT	DFS700JT
电源电压/Power Supply	AC110-220V/60-50Hz	AC110-220V/60-50Hz	AC110-220V/60-50Hz	AC110-220V/60-50Hz
总功率/Power Consumption	450W	570W	800W	850W
最大封口尺寸/Max Sealing Size	400mm	550mm	650mm	800mm
外包装尺寸/Shipment Dimension				
毛重/Gross Weight	15kg	21kg	23kg	26kg

## HP系列色带打码机 Coloured-tape Printer

捆霸牌系列打码机广泛应用于食品、医药等行业，具有印刷精美，字迹牢固，无污染，换字方便等优点，能完美印刷各种包装材料，如：PT、PE、OPP、铝箔、纸等

KUNBA series printer is widely used in food, medicine and other industries, with nice printing, legible writing, non-polluting, changing the word easy, etc., which can print a variety of packaging materials, such as: PT, PE, OPP, aluminum foil, paper

手压色带打码机  
Hand ribbon printer

### HP-241S



#### 技术参数 Technology Parameters

型号/Model	HP-241S
电源电压/Power Supply	AC110-220V/60-50Hz
总功率/Power Consumption	100W
印字行数/Printing Lines	1-3行 (line)
活字/Word's Sample	阿拉伯数字、中英文均可English、Numbers
速度/Speed	20-120pcs/min
外包装尺寸/Shipment Dimension	240 x 240 x 140mm
毛重/Gross Weight	2.8kg

电动色带打码机(电脑版)  
Electrical ribbon printer(micro computer)

### HP-23



#### 技术参数 Technology Parameters

型号/Model	HP-23
电源电压/Power Supply	AC110-220V/60-50Hz
总功率/Power Consumption	120W
印字行数/Printing Lines	1-3行(lines)
活字/Word's Sample	阿拉伯数字、中英文均可English、Numbers
速度/Speed	20-120pcs/min
外包装尺寸/Shipment Dimension	295 x 285 x 350mm
毛重/Gross Weight	10.5kg

电动色带打码机  
Electrical ribbon printer

### HP-450DT

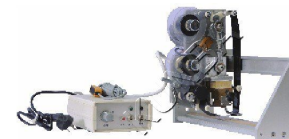

#### 技术参数 Technology Parameters

型号/Model	HP-450DT
电源电压/Power Supply	AC110-220V/60-50Hz
总功率/Power Consumption	120W
印字行数/Printing Lines	1-3行(lines)
活字/Word's Sample	阿拉伯数字、中英文均可English、Numbers
速度/Speed	20-120pcs/min
外包装尺寸/Shipment Dimension	410 x 200 x 250mm
毛重/Gross Weight	10kg

气动色带打码机  
Pneumatic ribbon printer

### HP-4500QT



#### 技术参数 Technology Parameters

型号/Model	HP-45QT
电源电压/Power Supply	AC110-220V/60-50Hz
总功率/Power Consumption	60W
印字行数/Printing Lines	1-3行(lines)
活字/Word's Sample	阿拉伯数字、中英文均可English、Numbers
速度/Speed	20-120pcs/min
外包装尺寸/Shipment Dimension	410 x 200 x 250mm
毛重/Gross Weight	8kg

## 半自动捆扎机系列 Semi-automatic strapping machine series

捆霸牌系列捆扎机是使用打包带缠绕产品或包装件，然后收紧并将两端通过热效应熔融或使用包扣等材料连接的机器。打包机的功用是使塑料带能紧贴于被捆扎包件表面，保证包件在运输、贮存中不因捆扎不牢而散落，广泛适用于各行各业。

KUNBA strapping machine takes polythene plastic strap as binding material, which is mainly used in binding paper carton, wooden box and paper parcels in sectors of business, postal service, railway, bank, food, pharmaceutical and publishing.

自动捆扎机  
Strapping machine

**KZB-I**



### 技术参数 Technology Parameters

型号/Model	KZB-I
电源电压/Power Supply	AC220-240V/50Hz
总功率/Power Consumption	250W
捆扎速度/Capacity	1.8秒 (S) /道 (time)
捆扎力/Strapping Tension	40-480N可调 (Adjustable)
捆扎带宽/Strap Width	9-15mm
外包装尺寸/Shipment Dimension	925 x 585 x 810mm
毛重/Gross Weight	85Kg

自动捆扎机  
Strapping machine

**KZB-II**



### 技术参数 Technology Parameters

型号/Model	KZB-II
电源电压/Power Supply	AC220-240V/50Hz
总功率/Power Consumption	250W
捆扎速度/Capacity	1.8秒 (S) /道 (time)
捆扎力/Strapping Tension	40-480N可调 (Adjustable)
捆扎带宽/Strap Width	9-15mm
外包装尺寸/Shipment Dimension	1470 x 580 x 510mm
毛重/Gross Weight	80Kg

可调型自动捆扎机  
Adjustable semi-automatic strapping machine

**KZB-I**



### 技术参数 Technology Parameters

型号/Model	KZB-I
电源电压/Power Supply	AC220-240V/50Hz
总功率/Power Consumption	250W
捆扎速度/Capacity	1.8秒 (S) /道 (time)
捆扎力/Strapping Tension	40-480N可调 (Adjustable)
捆扎带宽/Strap Width	9-15mm
外包装尺寸/Shipment Dimension	895 x 580 x 730mm
毛重/Gross Weight	110Kg

可调型自动捆扎机  
Adjustable semi-automatic strapping machine

**KZB-II**



### 技术参数 Technology Parameters

型号/Model	KZB-II
电源电压/Power Supply	AC220-240V/50Hz
总功率/Power Consumption	250W
捆扎速度/Capacity	1.8秒 (S) /道 (time)
捆扎力/Strapping Tension	40-480N可调 (Adjustable)
捆扎带宽/Strap Width	9-15mm
外包装尺寸/Shipment Dimension	1470 x 580 x 505mm
毛重/Gross Weight	90Kg

## 自动捆扎机系列 Automatic strapping machine

全自动捆扎机  
Automatic strapping machine

**SK-2A**



### 技术参数 Technology Parameters

型号/Model	SK-2A
电源电压/Power Supply	AC3 380V/50Hz
总功率/Power Consumption	0.75kw
捆扎速度/Strapping Speed	≤2.5秒 (s) /道 (time)
捆扎尺寸/Strapping Size	800 x 500mm
捆扎拉力/Strapping Tension	80kgs
PP包带/Tape Width	厚Thickness(0.6-1.2)mm 宽width(9-15)mm
外包装尺寸/Shipment Dimension	400 x 590 x 1500mm
毛重/Gross Weight	220kg

全自动捆扎机  
Automatic strapping machine

**MH-101A**



### 技术参数 Technology Parameters

型号/Model	MH-101A
电源电压/Power Supply	AC3 380V/50Hz
总功率/Power Consumption	0.75kw
捆扎速度/Strapping Speed	≤2.5秒 (s) /道 (time)
捆扎尺寸/Strapping Size	宽800mm*高度根据需定 can make especial size acording to your order
捆扎拉力/Strapping Tension	80kgs
PP包带/Tape Width	厚Thickness(0.6-1.2)mm 宽width(9-15)mm
外包装尺寸/Shipment Dimension	590 x 1500mm
毛重/Gross Weight	250kg

全自动捆扎机  
Automatic strapping machine

**MH-101B**

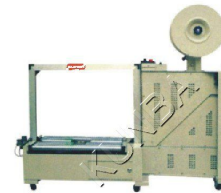

### 技术参数 Technology Parameters

型号/Model	MH-101B
电源电压/Power Supply	AC3 380V/50Hz
总功率/Power Consumption	0.75kw
捆扎速度/Strapping Speed	≤2.5秒 (s) /道 (time)
捆扎尺寸/Strapping Size	宽800mm*高度根据需定 can make especial size acording to your order
捆扎拉力/Strapping Tension	5-38kgs
PP包带/Tape Width	厚Thickness(0.6-1.2)mm 宽width(9-15)mm
外包装尺寸/Shipment Dimension	1810 x 640 x 1570mm
毛重/Gross Weight	290kg

栈板机  
Pallet strapping machine

**YL-130**



### 技术参数 Technology Parameters

型号/Model	YL-130
电源电压/Power Supply	AC220-240V/50Hz
总功率/Power Consumption	0.5kw
捆扎速度/Strapping Speed	1.8秒 (s) /道 (time)
PP包带/Tape Width	6-12mm
外包装尺寸/Shipment Dimension	1860 x 580 x 1500mm
毛重/Gross Weight	150kg

## BS 系列自动收缩包装机 BS series automatic shrinking machine

捆霸牌收缩封切设备广泛应用于食品、饮料、糖果、文化用品、五金工具、日用百货、化工用品等收缩包装。它是利用塑料收缩膜在受热的条件下均匀收缩的特性来包裹产品，具有美观，防潮防尘，防止氧化腐蚀等作用

BS series Shrink wrap machines is widely used in food, beverage, candy, stationery, hardware, groceries and chemical Packed with shrunked plastic film, products are tidy, moisture proof dust-proof and free from oxidation and corrosion.

### PVC膜收缩机 Shrink tunnel machine

## BS-400



连续热收缩包装机采用石英远红外管加热，收缩温度和输送速度稳定可调，包装之后的产品，能密封、防潮、防撞击，适用于多件物品裹紧包装和托盘包装。

输送部分有网状带和杆状链两种可供选择。

通用型(TY)适用PVC、PP、POF等材料，超长收缩隧道、智能

The continuous shrink packaging machine adopts quartz far-infrared tube as heating source. The shrinking temperature and convey speed are stable and adjustable. The packed products can be sealed well, prevented from getting damp and protected against knocks. It is suitable for tight wrapping packaging of many-pieces articles and trap packaging.

Mesh conveyor and rods conveyor available.

Overlong Shrinking tunnel, brainpower tempower temperature controller with figure, closing heat wind recycle inside.

#### 技术参数 Technology Parameters

型号/Model	BS400
电源电压/Power Supply	AC220-240V/50Hz
总功率/Power Consumption	可调 ≤6.5KW Adjustable
有效工件/Working Efficiency	350 × 150mm
输送载量/Conveyor Loading	500-600cup/hr.
输送速度/Conveyor Speed	0-10m/min
包装材料/Material	PVC
外包装尺寸/Shipment Dimension	1200 × 600 × 785mm
毛重/Gross Weight	100Kg

### PVC膜收缩机 Shrink tunnel machine

## BS-4535



#### 技术参数 Technology Parameters

型号/Model	BS4535
电源电压/Power Supply	380V/50Hz
总功率/Power Consumption	可调 ≤15KW Adjustable
有效工件/Working Efficiency	450 × 350mm
输送载量/Conveyor Loading	25kg Maximum
输送速度/Conveyor Speed	0-10m/min
包装材料/Material	PVC, POF, PE
外包装尺寸/Shipment Dimension	2150 × 690 × 1400mm
毛重/Gross Weight	230Kg

## 半自动系列封切、收缩包装机 Semi-auto sealing-cutting machine

### 半自动封切包装机 Semi-auto sealing and cutting packager

## FL-5045T



“L”型封切刀，包装物一次封切成型，氟特氟龙不粘层封刀，封切不粘膜，且封口整齐不开裂，产品经封切后自动输送到收缩机，进行收缩包装。

L-type sealing knife achieves sealing one time. TEFLON one-adhesive layer, non-adhesive sealing film result in sealing neat and without splitting. After sealing, materials will be transmit into tunnel to shrink automatically.

#### 技术参数 Technology Parameters

型号/Model	FL-5045T
电源电压/Power Supply	AC220-240V/50Hz
总功率/Power Consumption	1.2KW
最大封切面积/Max Packing Size	C500-350mm
工作效率/Working Efficiency	800-1000/h
外包装尺寸/Shipment Dimension	F1400 × W700 × H1000mm
毛重/Gross Weight	110Kg

### 恒温收缩包装机 Orstable shrink packager

## SM-4525



欧美先进螺旋运风技术，收缩效率特佳，日产量高达3万-5万件，适合特大批量的收缩包装，采用名厂电机，满足大负荷，长时间运转的需要，输送滚轴外套材料是硅胶，不会损坏包装物。彻底解决底部难收缩的困扰。有三层隔热装置，总功率只需6-7KW，与“L”型封

Advanced European spiral blower technology results in special shrinking efficiency. with daily production capacity up to 30000-50000 pieces, applicable to batch production. Famous brand motors are adopted to meet the requirement of heavy load and long operation them. There-layer insulating devices result in heat energy loss no higher than 6-7kw. L-type automatic

#### 技术参数 Technology Parameters

型号/Model	SM-4525
电源电压/Power Supply	AC3 φ-380V/50Hz
总功率/Power Consumption	可调 ≤6KW Adjustable
有效工件/Working Efficiency	400 × 200mm
输送载量/Conveyor Loading	10kg Maximum
输送速度/Conveyor Speed	0-10m/min
包装材料/Material	PVC
外包装尺寸/Shipment Dimension	1330 × 750 × 1400mm
毛重/Gross Weight	170Kg